

Judul Karya Ilmiah : Automation System Hydroponic Using Smart Solar Power Plant Unit
 Penulis : **Simon Siregar**, Marlindia Ike Sari, Rakhmi Jauhari
 Bentuk Karya : Jurnal Internasional: Jurnal Teknologi 2016
 Jurnal : Jurnal Teknologi Vol. 78, No 5-7, hal 55-60, 2016
 E-ISSN : 2180-3722
 Publisher : Penerbit Universiti Teknologi Malaysia
 Terindeks : Scopus Q3
 SJR : 0.18
 Link Scimagojr : <https://www.scimagojr.com/journalsearch.php?q=21100220470&tip=sid>
 Link Full Paper : <https://jurnalteknologi.utm.my/index.php/jurnalteknologi/article/view/8713/5177>
 Similarity : 15%

SJR Enter Journal Title, ISSN or Publisher Name

menu

Jurnal Teknologi (Sciences and Engineering)

Country: Malaysia - **14** SIR Ranking of Malaysia

Subject Area and Category: Engineering (Engineering (miscellaneous)) H Index

Publisher: Penerbit Universiti Teknologi Malaysia

Publication type: Journals

ISSN: 21803722, 01279696

Coverage: 2010-ongoing

Join the conversation about this journal

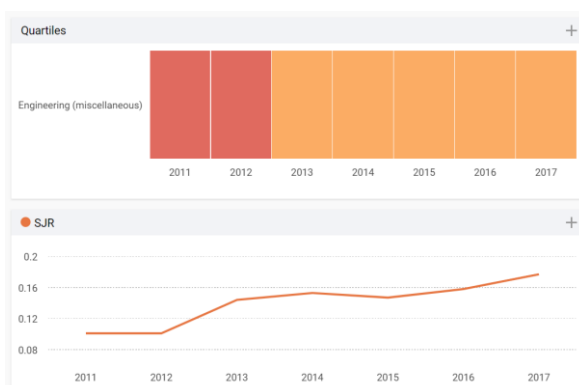

Jurnal Teknologi (Sciences and Engineering)

Q3 Engineering (miscellaneous) best quartile

SJR 2017 0.18

powered by scimagojr.com



Home > **Vol 81, No 1**

Jurnal Teknologi

SCOPE OF PUBLICATION

Jurnal Teknologi welcomes quality research in the area of Mathematics, Natural Sciences (Biological Sciences, Physical Sciences: Physics, Chemistry, Astronomy, Earth Science) and Applied Mathematics and Natural Sciences (Building Physics, Mechanical Engineering, Chemical Engineering, Civil Engineering, Material Science, Biotechnology, Medical Engineering).

Indexed by: SCOPUS, ESCI-WOS, ACI, MYCITE, MYJURNAL

HISTORY OF JURNAL TEKNOLOGI

Jurnal Teknologi was first published in April 1977, then known as Teknologi. Its publications, however, only began to take off on regular basis in 1992.

The publication of Jurnal Teknologi aims to be the forum for academics and practitioners to write and publish their latest work. Specifically, the journal serves to disseminate to the public results of current and on-going research projects conducted by UTM academics in various fields.

As the journal continues to grow, starting from June 1999, with volume No. 30, Jurnal Teknologi was revamped. The journal now comes in a set of six series (A – F), published twice a year (June and December). Each series specifically focuses on specialized fields: A (Manufacturing, Advanced Materials, Energy, and Transport); B (Construction, Design, and Planning); C (Science and Mathematics); D (Electronics, Control, Communication, and Information Technology); E (Management, Education, and Social Sciences) and F (Environment and Process Technology).

Starting from year 2010, six series of Jurnal Teknologi were merged into two series known as: Jurnal Teknologi (Science and Engineering) and Jurnal Teknologi (Social Sciences). Published online six time a year (January, March, May, July, September and November). On 2016, Jurnal Teknologi (Sciences and Engineering) will be published every month. However, under new management, Jurnal Teknologi (Science and Engineering) will be published online six time a year (January, March, May, July, September and November) on 2017.

On 2014, Jurnal Teknologi (Sciences & Engineering) has been separated from Jurnal Teknologi (Social Sciences). Jurnal Teknologi (Social Sciences) is now known as Sains Humanika.

Jurnal Teknologi (Sciences & Engineering) is now indexed by **SCOPUS**.

[Journal Help](#)

USER

Username
 Password
 Remember me

NOTIFICATIONS

- [View](#)
- [Subscribe](#)

JOURNAL CONTENT

Search
 Search Scope
 All

Browse

- [By Issue](#)
- [By Author](#)
- [By Title](#)

FONT SIZE

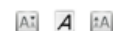

INFORMATION

- [For Readers](#)
- [For Authors](#)
- [For Librarians](#)

CURRENT ISSUE



[Home](#) > [About the Journal](#) > **Editorial Team**

Editorial Team

Chief Editors

[Jurnal Teknologi Editorial Team](#)

[Professor Dr. Rosli Md Illias](#), Universiti Teknologi Malaysia, Malaysia

Editors

[Professor Datuk Dr. Ahmad Fauzi Ismail](#), Universiti Teknologi Malaysia, Malaysia

[Professor Dr. Muhammad Hisyam Lee](#), Universiti Teknologi Malaysia, Malaysia, Malaysia

[Professor Dr. Ruzairi Abdul Rahim](#), Universiti Tun Hussein Onn Malaysia, Malaysia

[Professor Dr. Azman Hassan](#), Universiti Teknologi Malaysia, Malaysia

[Professor Dr. Hadi Nur](#), Universiti Teknologi Malaysia, Malaysia

[Professor Dr. Mohammad Nazri Mohd. Jaafar](#), Universiti Teknologi Malaysia, Malaysia

[Professor Dr. Zainal Salam](#), Universiti Teknologi Malaysia, Malaysia

[Professor Dr. Rosli Hussin](#), Universiti Teknologi Malaysia, Malaysia

[Professor Dr. Mohd. Rosli Hainin](#), School of Civil Engineering Universiti Teknologi Malaysia, Malaysia

[Professor Dr. Mohd Shahir Shamsir Omar](#), Universiti Teknologi Malaysia, Malaysia

[Professor Dr. Safian Sharif](#), Universiti Teknologi Malaysia, Malaysia

[Professor Sr. Dr. Mazlan Hashim](#), Universiti Teknologi Malaysia, Malaysia

[Professor Dr. Mohd Saberi Mohamad](#), Universiti Malaysia Kelantan, Malaysia

[Professor Dr. Hesham Ali El-Enshasy](#), Universiti Teknologi Malaysia, Malaysia

[Assoc. Prof. Dr. Norhazilan Md Noor](#), Universiti Teknologi Malaysia, Malaysia

[Dr. Mohd Hafiz Dzarfan Othman](#), Universiti Teknologi Malaysia, Malaysia

[Dr. Pei Sean Goh](#), Universiti Teknologi Malaysia, Malaysia

[Dr. Syafiqah Saidin](#), Universiti Teknologi Malaysia, Malaysia, Malaysia

[Dr. Dalila Mat Said](#), Universiti Teknologi, Malaysia, Malaysia

Editorial Board

[Professor I. S. Jawahir](#), University of Kentucky, United States

[Professor Dr. Xianshe Feng](#), University of Waterloo, Canada

[Professor Dr. Mustafizur Rahman](#), National University of Singapore, Singapore

[Professor Dr. William McClusky](#), University of Ulster, United Kingdom

[Professor Vijay K. Arora](#), Wilkes University, United States

[Assoc. Prof. Dr. G. Arthanareeswaran](#), National Institute of Technology, Tiruchirapalli, INDIA

[Assoc. Professor Dr. Arun M Isloor](#), National Institute of Technology Karnataka, INDIA

[Professor Dr. Jamaliah Md Jahim](#), Universiti Kebangsaan Malaysia, Malaysia

[Professor Dr. Che Hassan Che Haron](#), Universiti Kebangsaan Malaysia, Malaysia

AUTOMATION SYSTEM HYDROPONIC USING SMART SOLAR POWER PLANT UNIT

Simon Siregar*, Marlindia Ike Sari, Rakhmi Jauhari

Faculty of Applied Science School, Telkom University
Bandung, Jawa Barat, Indonesia

Article history

Received

20 June 2015

Received in revised form

18 November 2015

Accepted

8 Jan 2016

*Corresponding author
simon.siregar@tass.telkomuniversity
.ac.id

Graphical abstract

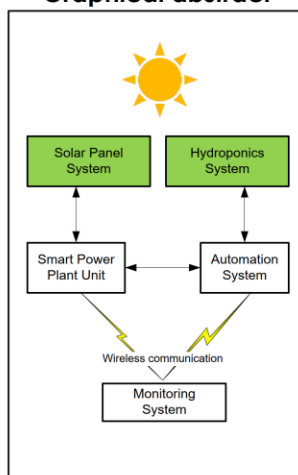

Abstract

Automation system hydroponic is one of the farming solution. There are several problems in hydroponic that can be divided into two parts. First part is the hydroponic system. The system needs to control and monitor temperature, pH and distribution of water. Second part is the power supply, generally it run from conventional electrical energy and it should continue to run all the time. Electrical energy needs is increasing from time to time. In this research, there are two possible solutions to solve the problem. The first possible solution is the automation for hydroponics system that would measure and control temperature, pH and water level in water tank. The second possible solution is smart solar power plant unit which function as primary power supply and will shift to conventional electrical energy if there is no adequate energy to run the automation for hydroponics system. The smart solar power plant unit monitor the intensity of light, voltage and electrical current between battery and DC to AC converter and the voltage that produced from solar panel. The value of temperature, pH and water level in water tank, intensity of light, electrical current and voltage will be sent to a server by wireless communication. The result of this research is a prototype of automation system hydroponic using smart solar power plant that can monitor and control pH, temperature, water level, intensity of light, electrical current and voltage.

Key words: Automation system; wireless monitoring system; hydroponic; solar panel

© 2016 Penerbit UTM Press. All rights reserved

1.0 INTRODUCTION

The current resurgence of interest in the use of renewable energy is driven by the need to reduce the high environmental impact of fossil-based energy systems and food safety in agricultural production systems [1]. Monitoring and Control is a key enabling technology for the deployment of renewable energy systems in agricultural production system. One of monitoring and controlling system in agricultural production system is greenhouse food production that often termed controlled environment agriculture (CEA) which usually accompanies hydroponics. [2]

Hydroponics is a technology for growing plants in nutrient solutions (water and fertilizers) with or without the use of an artificial medium (for example: sand, gravel, vermiculite, rock wool, peat moss, coir, sawdust) to provide mechanical support. Several studies have shown that hydroponics has basic requirements of hydroponics, there are growing medium, mineral nutrients, nutrient solution, temperature, water, light and air as shown in table 1 [3].

Due to the high energy demands, improved energy efficiency research for hydroponic can be found on [4]. One possible way to make commercial hydroponics more sustainable and suitable alternative would be to relocate the greenhouse to an area where there

are cheap and renewable sources of energy, such as solar, geothermal or wind power.

In this research, a prototype of automation for hydroponics system using solar power as renewable energy source is proposed. In this prototype, several parameters are measured to control the hydroponics system and solar power energy. The parameters that is measured for control and monitoring the hydroponics system are temperature, light intensity, nutrient solution. For the solar power energy, the parameters that is measured for control and monitoring are voltage and current from the solar panel system.

Table 1 Basic requirement of Hydroponics [3]

No.	Parameter	Common Value
1.	Growing Medium	Coco coir fiber, Rockwool, Perlite, Vermiculite, LECA, Expanded clay, Crushed granite, Sand, Scoria, Gravel
2.	Mineral Nutrients	17 Elements
3.	Nutrient Solution	The E.C. (electrical conductivity) value 2.5, the pH value 5.5 – 6.5.
4.	Temperature	High temperature tend to accelerate the growth, generally the temperature is 22°C-28°C
5.	Wind	Higher wind tend to evaporate water
6.	Water	Should have conductivity less than 500 uS/cm, or a total salt concentration less than 350 ppm.
7.	Light	Areas that already get sunlight will need fewer hydroponic lights than a hydroponic garden grown in a fully enclosed room.

2.0 GENERAL CONCEPT OF THE SYSTEM

In this proposed system consists of 3 parts, namely: Automation for Hydroponic System, Smart Solar Power Plant Unit and Monitoring System. The general concept of the system can be seen in figure 1.

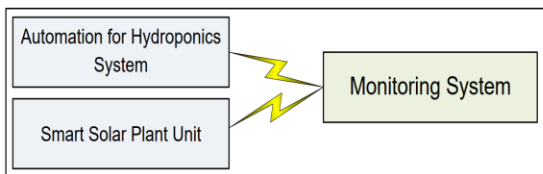

Figure 1 General concept of the proposed system

2.1 Automation for Hydroponic System

Automation for Hydroponic System, based on figure 2, consists of Sensors, microcontroller, actuators and communication module, which monitor and control several parameters on hydroponics system : Temperatur, water pH, light intensity and water level on water tank. The sensors that was used in this research are LM35 (temparature sensor), pH meter (pH sensor),

LDR (light intensity sensor) and Ultrasonic Sensor (water level sensor). Microcontroller that was used in this research is Atmega 328 with 32K Bytes In-System Self-Programmable Flash progam memory [5]. This microcontroller is programmed using Arduino IDE. On the actuator, there are three relay, that activate Water Pump, Peltier and Led Grow Light, Buzzer and LCD Display. Peltier module, which known as thermoelectric module, is an electrical module, which produces atemperature difference with current flow. The emergence of thetemperature difference is based on the Peltier effect designatedafter Jean Peltier. The thermoelectric module is a heat pump andhas the same function as a refrigerator[6]. LED Grow Light, which commonly used blue LED (with wavelength 380-480 nm) and red LED (with wavelength 630-730 nm), with could provide an alternative lighting source for hydroponically grown miniature lettuce[7]. In communication module, in this research used APC 220 433 MHz module. This module function as transmitter an receiver to send and receive information and control signal.

This automation for hydroponics system function is to detect parameters and perform an action to control the condition within specified parameter.

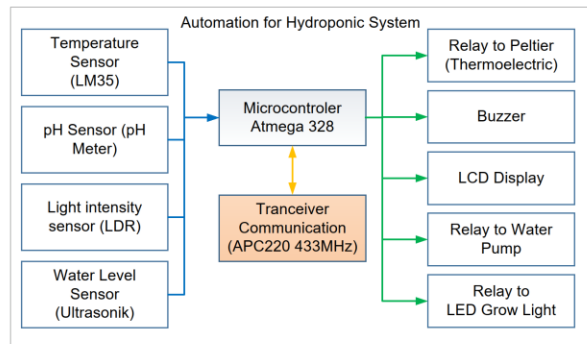

Figure 2 Block diagram of the automation system

2.2 Smart Solar Power Plant Unit

Smart Solar Power Plant unit, based on figure 3, consists ofSolar Panel Set, Sensor, actuators and communication module, which monitor and control two parameters on Smart Solar Power system : Current and voltage between Battery and Inverter DC to AC and voltage between solar panel and solar charge controller.

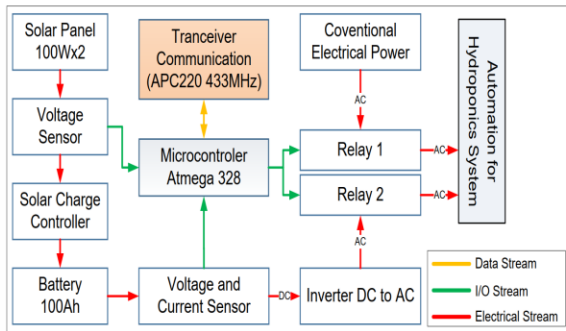

Figure 3 Block diagram of Smart Solar Power Plant Unit

The sensors that was used in this research are voltage and current sensor. The type of voltage and current sensor is voltage divider sensor and ACS712 current sensor[8].The type of microcontroller is Atmega 328 with 32K Bytes In-System Self-Programmable Flash program memory and programmed using Arduino IDE. On the actuator, there are two relay, that activate electrical current from Conventional Electrical Power and electrical current from inverter DC to AC. In communication module, this system used APC 220 433 MHz module. This module function as transmitter and receiver to send and receive information and control signal.

This Smart Solar Power Plant Unit function is to detect voltage and current stream and perform an action to switch power between solar panel and conventional electrical power.

2.3 Monitoring System

Monitoring System, based on figure 4, consists of Monitor, which is used to display information from Automation for Hydroponic System and Smart Solar Power Unit, Raspberry Pi Server, that function as a server that collect data and display data to monitor, and communication module, which send control signal and receive data from Smart Solar Power Unit and Automation for Hydroponics System. Every data which received from Hydroponics System and Power Unit is then processed into graphical display using GAMBAS application version 3.1.1.

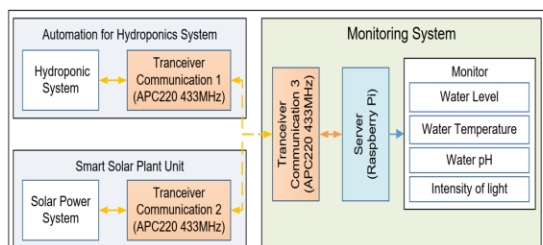

Figure 4 Block diagram of the Monitoring System

2.4 Smart Solar Power Plant Unit Flow Chart

After the system is configured accordance to the proposed concept, figure 5 shows the flowchart used for the software of Smart Solar Plant Unit. The state of using conventional electrical power or solar power can be varied depends on the condition of the battery.

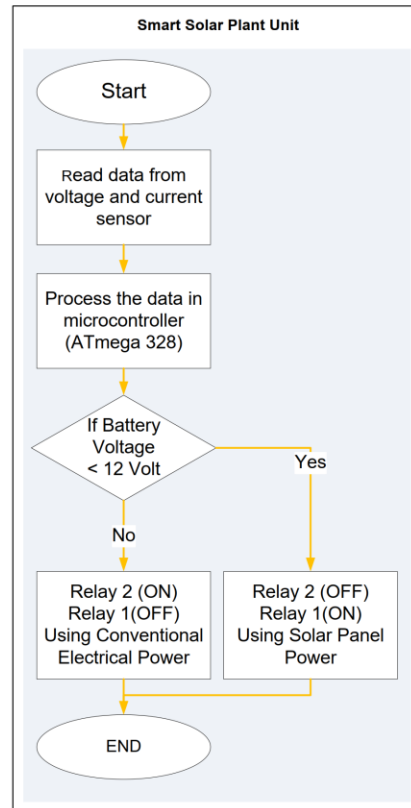

Figure 5 Flow Chart of the Smart Solar Plant Unit System

2.5 Automation for Hidroponics System Flow Chart

Figure 6 shows the flowchart that used for the software of Automation for Hydroponics System. The state of peltier, water pumps, buzzer and LED grow light depends on the condition of water and intensity of light.

2.6 Monitoring System Flow Chart

Figure 7 shows the flowchart that used for the software of Monitoring System. The server send signal 1 or 2 then in sequentially receive data from Hydroponics system and power plant unit. The data that was received on server are temperature, water level, pH water, light intensity, current and voltage.

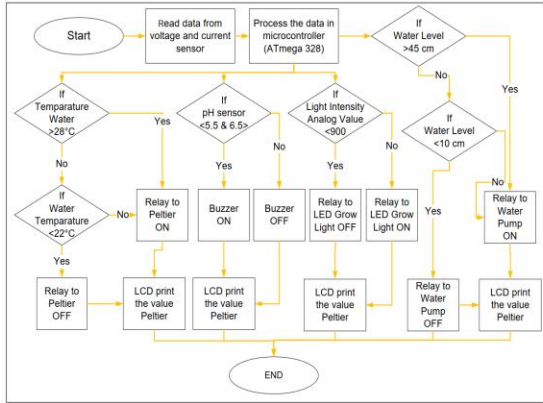

Figure 6 Flow Chart of Automation for Hydroponics System

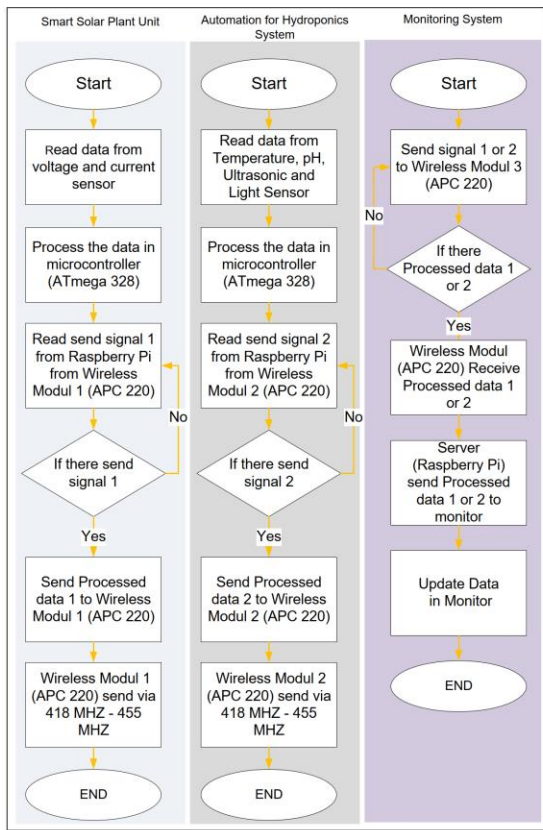

Figure 7 Blockdiagram of the Monitoring System

3.0 RESULTS AND DISCUSSION

3.1 Hardware Result

Figure 8 shows the hydroponic system with several type of hydroponics plantation. Figure 9 shows hydroponics

system with Grow LED Light in On state. Figure 10 shows the automation for hydroponics system with intensity of light is been displayed in LCD Display. Figure 11 shows the smart solar panel unit with 2 solar panel 100 Watt with 100 Ah battery. The last figure, figure 12 shows water level, temperature value, analog LDR value, pH sensor value, current and voltage value to the monitor display which was processed from Raspberry Pi.



Figure 8 Hydroponic System



Figure 9 Hydroponic with Grow LED Light

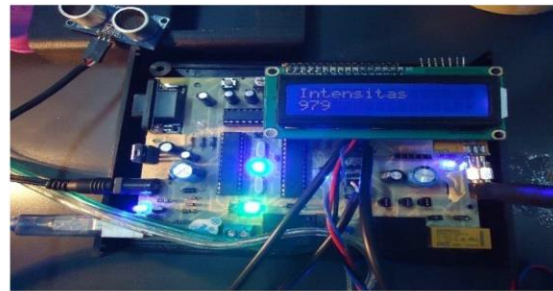

Figure 10 The automation for hydroponic system

3.2 Experimental Result

After programming the prototype, the test is conducted to test the function of the prototype. Testing parameter that will be tested are, LDR value which affect the state of Grow LED Light, LM35 value which affect the state of peltier, Ping(ultrasonic sensor) which affect the state of Pump and pH sensor that affect the state of Buzzer.



Figure 11 Smart Power Plant Unit

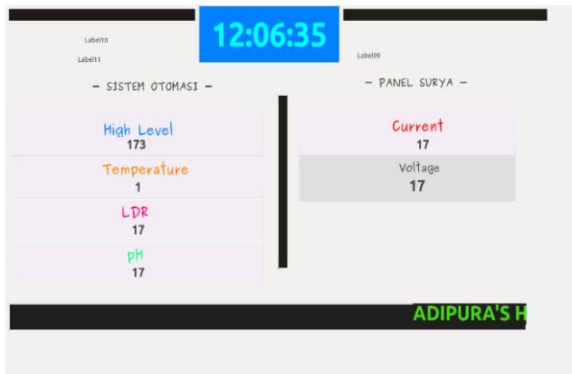

Figure 12 Monitoring System which shown in monitor display

The duration for conducting the test is 15 minutes in the morning, noon and afternoon. The data is taken every 3 minutes. This test is done to check whether the system is run according to design. The result of the test can be seen in table 2, 3 and 4.

Table 2 Testing System at 9:00 to 9:15 pm

LDR (Analog Value)	Grow LED	LM35 (°C)	Peltier	Ping (cm)	Pump	pH	Buzzer
267	Off	25.0	Off	15	Off	6.4	Off
357	Off	27.1	Off	26	Off	6.4	Off
357	Off	29.6	On	32	On	6.4	Off
340	Off	31.0	On	42	Off	7.1	Off
340	Off	25.1	On	49	On	6.4	Off

Table 3 Testing System at 12:48 to 13:03 pm

LDR (Analog Value)	Grow LED	LM35 (°C)	Peltier	Ping (cm)	Pump	pH	Buzzer
388	Off	27.3	Off	40	off	6.4	Off
439	Off	31.2	On	49	On	7.1	On
439	Off	25.2	On	29	On	7.5	On
443	Off	22.0	On	17	On	7.5	On
393	Off	21.5	Off	9	Off	6.4	Off

Table 4 Testing System at 4:30 to 4:45 pm

LDR (Analog Value)	Grow LED	LM35 (°C)	Peltier	Ping (cm)	Pump	pH	Buzzer
856	On	28.0	On	5	Off	6.4	Off
760	On	28.1	On	16	Off	6.4	Off
880	On	23.1	On	28	Off	6.4	Off
880	On	24.4	On	39	Off	6.4	Off
889	On	22.1	On	48	On	6.4	Off

3.3 Discussion and Analysis

From the testing table 2, 3 and 4, we give some analysis:

1. For the light intensity, the average of light intensity is 535.2. The system is ran accordance to the design, where the Grow LED light will turn to ON state if the analog value of the LDR is more than 900.
2. The average water temperature is 25.46°C. The system ran accordance to the design, where the Peltier will turn to ON state if the water temperature more than 28°C and will still in ON state until the water temperature below 22°C.
3. The water level sensor is ran accordance to the design, which run the water pump when distance, which measured by ping (ultrasonic) sensor, is more than 45 cm. The water pump will still in ON state until the distance is less than 10 cm.
4. The level of acidity (pH) in the water reservoir is on level 6.43, which is in good pH value for plant growth.

4.0 CONCLUSION

A prototype of automation for hydroponics system with smart solar panel unit is proposed. In this prototype, the system ran accordance the prototype design. The communication module work as designed. The data that send from the prototype can be received in the Raspberry Pi Server which showed the information in to display monitor. Currently, the prototype is being improved to control pH nutrient mineral and nutrient solution automatically.

Acknowledgement

The authors would like to thank to Department research and community service Telkom University, Indonesia, for providing financial support for this work through Internal Funded Research grant.

References

- [1] Pinho P., Jokinen K. and Halonen L., 2012. Horticultural Lighting—Present and Future Challenges, *Lighting Research and Technology*, 44(4): 427-437.
- [2] Jensen M. H. Hydroponics Worldwide- A Technical Overview. *University of Arizona, School of Agriculture*.
- [3] Murali Mugundhan. R, Soundaria. M, Maheswari. V, Santhakumari. P And Gopal. V. 2011. Hydroponics.- A Novel Alternative for Geoponic Cultivation of Medicinal Plants and Food Crops. *International Journal of Pharma and Bio Sciences*. 2(2): 286-296.
- [4] Barbosa G. L., Gadelha F. D. A., Kublik N., Proctor A., Reichelm L., Weissinger E., Wohlleb G. M. and Halden R.U. 2015. Comparison of Land, Water and Energy Requirements of Lettuce Grown Using Hydroponic vs. Conventional Agriculture Method. *International Journal of Environmental Research and Public Health*. 12(6): 6879-6891.
- [5] ATmel 8-bit AVR Microcontroller with 4/8/16/32K Bytes In-System Programmable Flash, [Online]. From: <http://www.atmel.com/images/doc8161.pdf> [Accessed on 23 September 2015].
- [6] Introduction of Thermoelectric Coolers [Online]. From: http://www.deltron.ch/pdf/produkte/peltier/kuehleinheit_kurz_erklaert_e.pdf [Accessed on 24 September 2015]
- [7] Kobayashi K., Amore T., and Lazaro M. 2013. Light-Emitting Diodes (LEDs) for Miniature Hydroponic Lettuce Miniature *Optics and Photonics Journal*. 3:74-77
- [8] Siregar S. 2014. Solar Panel and Battery Street Light Monitoring System Using GPRS Communication System. *International Journal of Applied Engineering Research (IJAER)*. 9(23): 7844-7848.

AUTOMATIONSYSTEM HYDROPONIC USING SMART SOLAR POWER PLANT UNIT

By Simon Siregar

WORD COUNT

2978

TIME SUBMITTED

21-OCT-2017 10:14AM

PAPER ID

32356514

AUTOMATION SYSTEM HYDROPONIC USING SMART SOLAR POWER PLANT UNIT

Article history

Received

TBA

Received in revised form

TBA

Accepted

TBA

Simon Siregar, Marlindia Ike Sari, Rakhmi Jauhari*

6

Faculty of Applied Science School, Telkom
University Bandung, Jawa Barat, Indonesia.

*Corresponding author

simon.siregar@tass.telkomuniversity.ac.id

Graphical abstract

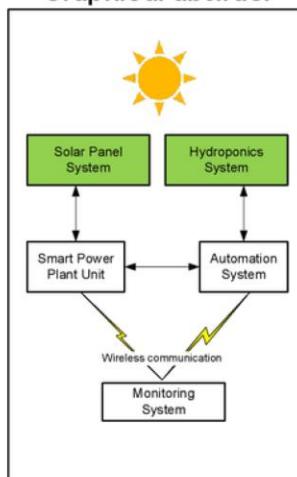

Abstract

Automation system hydroponic is one of the farming solution. There are several problems in hydroponic that can be divided into two parts. First part is the hydroponic system. The system needs to control and monitor temperature, pH and distribution of water. Second part is the power supply, generally it run from conventional electrical energy and it should continue to run all the time. Electrical energy needs is increasing from time to time. In this research, there are two possible solutions to solve the problem. The first possible solution is the automation for hydroponics system that would measure and control temperature, pH and water level in water tank. The second possible solution is smart solar power plant unit which function as primary power supply and will shift to conventional electrical energy if there is no adequate energy to run the automation for hydroponics system. The smart solar power plant unit monitor the intensity of light, voltage and electrical current between battery and DC to AC converter and the voltage that produced from solar panel. The value of temperature, pH and water level in water tank, intensity of light, electrical current and voltage will be sent to a server by wireless communication. The result of this research is a prototype of automation system hydroponic using smart solar power plant that can monitor and control pH, temperature, water level, intensity of light, electrical current and voltage.

Key words: Automation system; Wireless Monitoring system; Hydroponic; Solar Panel

© 2015 Penerbit UTM Press. All rights reserved

1.0 INTRODUCTION

8

The current resurgence of interest in the use of renewable energy is driven by the need to reduce the high environmental impact of fossil-based energy systems and food safety [14] agricultural production systems [1]. Monitoring and Control is a key enabling technology for the deployment of renewable energy systems in agricultural production system. One of monitoring and controlling system in agricultural production system is greenhouse food production that often termed controlled environment agriculture (CEA) which usually accompanies hydroponics. [2]

Hydroponics is a technology for growing plants in nutrient solutions (water and fertilizers) with or without the use of an artificial medium (for example: sand, gravel, vermiculite, rock wool, peat moss, coir, sawdust)

to provide mechanical support. Several studies have shown that hydroponics has basic requirements of hydroponics, there are growing medium, mineral nutrients, nutrient solution, temperature, water, light and air [15] shown in table 1 [3].

Due to the high energy demands, improved energy efficiency research for hydroponic can be found on [4]. One possible way to make commercial hydroponics a more sustainable and suitable alternative would be to relocate the greenhouse to an area where there are cheap and renewable sources of energy, such as solar, geothermal or wind power.

In this research, a prototype of automation for hydroponics system using solar power as renewable energy source is proposed. In this prototype, several parameters are measured to control the hydroponics system and solar power energy. The parameters that is

measured for control and monitoring the hydroponics system are temperature, light intensity, nutrient solution. For the solar power energy, the parameters that is measured for control and monitoring are voltage and current from the solar panel system.

Table 1 Basic requirement of Hydroponics [3]

No.	Parameter	Common Value
1.	Growing Medium	Coco coir fiber, Rockwool, Perlite, Vermiculite, LECA, Expanded clay, Crushed granite, Sand, Scoria, Gravel
2.	Mineral Nutrients	17 Elements
3.	Nutrient Solution	The E.C. (electrical conductivity) value 2.5, the pH value 5.5 – 6.5.
4.	Temperature	High temperature tend to accelerate the growth, generally the temperature is 22°C-28°C
5.	Wind	Higher wind tend to evaporate water
6.	Water	Should have conductivity less than 500 $\mu\text{S}/\text{cm}$, or a total salt concentration less than 350 ppm.
7.	Light	Areas that already get sunlight will need fewer hydroponic lights than a hydroponic garden grown in a fully enclosed room.

2.0 GENERAL CONCEPT OF THE SYSTEM

In this proposed system consists of 3 parts, namely: Automation for Hydroponic System, Smart Solar Power Plant Unit and Monitoring System. The general concept of the system can be seen in figure 1.

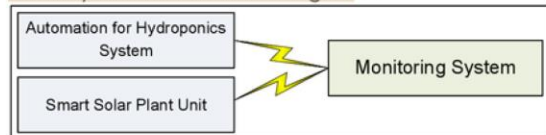

Figure 1 General Concept of the proposed System

2.1 Automation for Hydroponic System

Automation for Hydroponic System, based on figure 2, consists of Sensors, microcontroller, actuators and communication module, which monitor and control several parameters on hydroponics system : Temperatur, water pH, light intensity and water level on water tank. The sensors that was used in this research are LM35 (temparature sensor), pH meter (pH sensor), LDR (light intensity sensor) and Ultrasonic Sensor (water level sensor). Microcontroller that was used in this research is Atmega 328 with 32K Bytes In-System Self-Programmable Flash progam memory [5]. This microcontroller is programmed using Arduino IDE. On the actuator, there are three relay, that activate Water Pump, Peltier and Led Grow Light, Buzzer and LCD Display. Peltier module, which known as thermoelectric module, is an electrical module, which produces a temperature difference with current flow. The emergence of the temperature difference is based on the Peltier effect designated after Jean Peltier. The thermoelectric module is a heat pump and has the same function as a refrigerator[6]. LED Grow Light,

which commonly used blue LED (with wavelength 380-480 nm) and red LED (with wavelength 630-730 nm), with could provide an alternative lighting source for hydroponically grown miniature lettuce[7]. In communication module, in this research used APC 220 433 MHz module. This module function as transmitter an receiver to send and receive information and control signal.

This automation for hydroponics system function is to detect parameters and perform an action to control the condition within specified parameter.

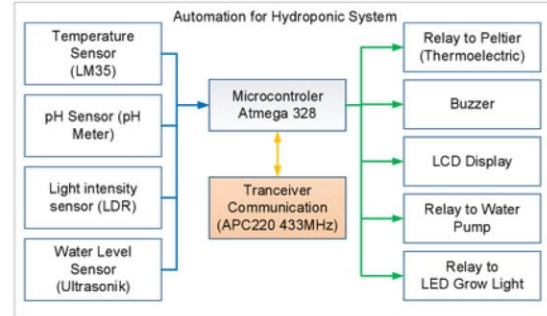

Figure 2 Block diagram of the Automation System

2.2 Smart Solar Power Plant Unit

Smart Solar Power Plant unit, based on figure 3, consists of Solar Panel Set, Sensor, actuators and communication module, which monitor and control two parameters on Smart Solar Power system : Current and voltage between Battery and Inverter DC to AC and voltage between solar panel and solar charge controller.

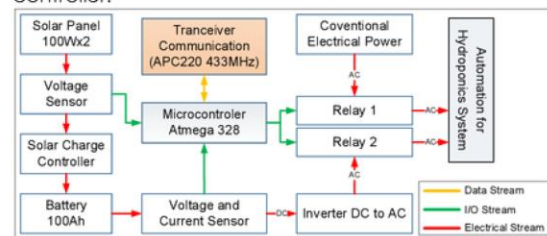

Figure 3 Block diagram of Smart Solar Power Plant Unit

The sensors that was used in this research are voltage and current sensor. The type of voltage and current sensor is voltage divider sensor and ACS712 current sensor[8]. The type of microcontroller is Atmega 328 with 32K Bytes In-System Self-Programmable Flash progam memory and programmed using Arduino IDE. On the actuator, there are two relay, that activate electrical current from Conventional Electrical Power and electrical current from inverter DC to AC. In communication module, this system used APC 220 433 MHz module. This module function as transmitter an receiver to send and receive information and control signal.

This Smart Solar Power Plant Unit function is to detect voltage and current stream and perform an action to switch power between solar panel and conventional electrical power.

2.3 Monitoring System

Monitoring System, based on figure 4, consists of Monitor, which is used to display information from Automation for Hydroponics System and Smart Solar Power Unit, Raspberry Pi Server, that function as a server that collect data and display data to monitor, and communication module, which send control signal and receive data from Smart Solar Power Unit and Automation for Hydroponics System. Every data which received from Hydroponics System and Power Unit is then processed into graphical display using GAMBAS application version 3.1.1.

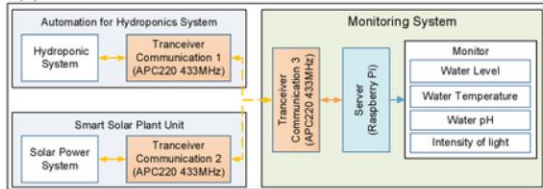

Figure 4 Block diagram of the Monitoring System

2.4 Smart Solar Power Plant Unit Flow Chart

After the system is configured accordance to the proposed concept, figure 5 shows the flowchart used for the software of Smart Solar Plant Unit. The state of using conventional electrical power or solar power can be varied depends on the condition of the battery.

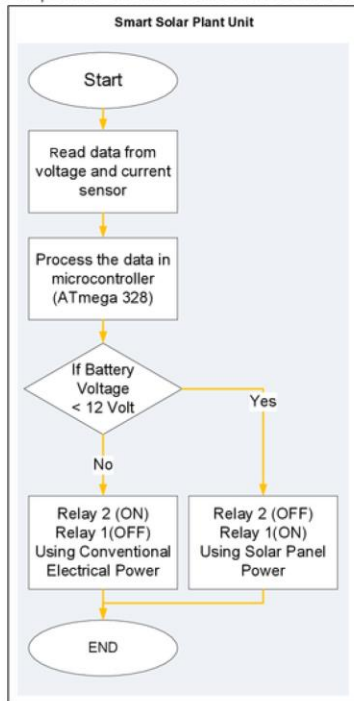

Figure 5 Flow Chart of the Smart Solar Plant Unit System

2.5 Automation for Hidroponics System Flow Chart

Figure 6 shows the flowchart that used for the software of Automation for Hydroponics System. The

state of peltier, water pumps, buzzer and LED grow light depends on the condition of water and intensity of light.

2.6 Monitoring System Flow Chart

Figure 7 shows the flowchart that used for the software of Monitoring System. The server send signal 1 or 2 then in sequentially receive data from Hydroponics system and power plant unit. The data that was received on server are temperature, water level, pH water, light intensity, current and voltage.

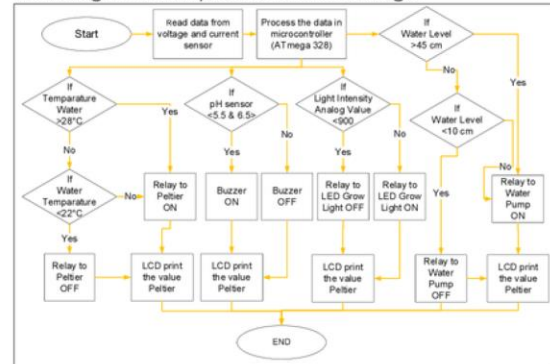

Figure 6 Flow Chart of Automation for Hydroponics System

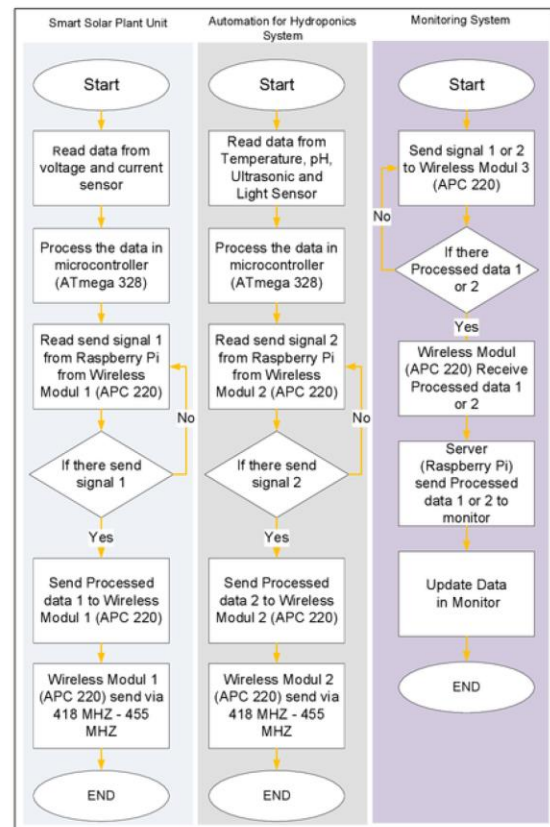

Figure 7 Block diagram of the Monitoring System

3.0 RESULTS AND DISCUSSION

3.1 Hardware Result

Figure 8 shows the hydroponic system with several type of hydroponics plantation. Figure 9 shows hydroponics system with Grow LED Light in On state. Figure 10 shows the automation for hydroponics system with intensity of light is been displayed in LCD Display. Figure 11 shows the smart solar panel unit with 2 solar panel 100 Watt with 100 Ah battery. The last figure, figure12 shows water level, temperature value, analog LDR value, pH sensor value, current and voltage value to the monitor display which was processed from Raspberry Pi.



Figure 8 Hydroponic System



Figure 9 Hydroponic with Grow LED Light



Figure 10 The automation for hydroponic system

3.2 Experimental Result

After programming the prototype, the test is conducted to test the function of the prototype. Testing parameter that will be tested are, LDR value which affect the state of Grow LED Light, LM35 value which affect the state of peltier, Ping(ultrasonic sensor) which

affect the state of Pump and pH sensor that affect the state of Buzzer.

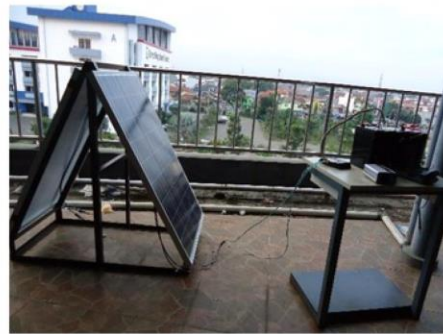

Figure 11 Smart Power Plant Unit



Figure 12 Monitoring System which shown in monitor display

The duration for conducting the test is 15 minutes in the morning, noon and afternoon. The data is taken every 3 minutes. This test is done to check whether the system is run according to design. The result of the test can be seen in table 2, 3 and 4.

Table 2 Testing System at 9:00 to 9:15 pm

LDR (Analog Value)	Grow LED	LM35 (°C)	Peltier	Ping (cm)	Pump	pH	Buzzer
267	Off	25.0	Off	15	Off	6.4	Off
357	Off	27.1	Off	26	Off	6.4	Off
357	Off	29.6	On	32	On	6.4	Off
340	Off	31.0	On	42	Off	7.1	Off
340	Off	25.1	On	49	On	6.4	Off

Table 3 Testing System at 12:48 to 13:03 pm

LDR (Analog Value)	Grow LED	LM35 (°C)	Peltier	Ping (cm)	Pump	pH	Buzzer
388	Off	27.3	Off	40	off	6.4	Off
439	Off	31.2	On	49	On	7.1	On
439	Off	25.2	On	29	On	7.5	On
443	Off	22.0	On	17	On	7.5	On
393	Off	21.5	Off	9	Off	6.4	Off

Table 4 Testing System at 4:30 to 4:45 pm

LDR (Analog Value)	Grow LED	LM35 (°C)	Peltier	Ping (cm)	Pump	pH	Buzzer
856	On	28.0	On	5	Off	6.4	Off
760	On	28.1	On	16	Off	6.4	Off
880	On	23.1	On	28	Off	6.4	Off
880	On	24.4	On	39	Off	6.4	Off
889	On	22.1	On	48	On	6.4	Off

3.3 Discussion and Analysis

From the testing table 2, 3 and 4, we give some analysis:

1. For the light intensity, the average of light intensity is 535.2. The system is ran accordance to the design, where the Grow LED light will turn to ON state if the analog value of the LDR is more than 900.
2. The average water temperature is 25.46°C. The system ran accordance to the design, where the Peltier will turn to ON state if the water temperature more than 28°C and will still in ON state until the water temperature below 22°C.
3. The water level sensor is ran accordance to the design, which run the water pump when distance, which measured by ping (ultrasonic) sensor, is more than 45 cm. The water pump will still in ON state until the distance is less than 10 cm.
4. The level of acidity (pH) in the water reservoir is on level 6.43, which is in good pH value for plant growth.

4.0 CONCLUSION

A prototype of automation for hydroponics system with smart solar panel unit is proposed. In this prototype, the system ran accordance the prototype design. The communication module work as designed. The data that send from the prototype can be received in the Raspberry Pi Server which showed the information in to display monitor. Currently, the prototype is being improved to control pH nutrient mineral and nutrient solution automatically.

Acknowledgement

The authors would like to thank to Department research and community service Telkom University, Indonesia, for providing financial support for this work through Internal Funded Research grant.

References

- [1] P. Pinho, K. Jokinen and L. Halonen, 2012, Horticultural Lighting—Present and Future Challenges, *Lighting Re-search and Technology*, Vol. 44, No. 4, pp. 427-437.

- [2] M. H. [7] [12] "Hydroponics Worldwide- A Technical Overview" University of Arizona, School of Agriculture.
- [3] Murali Mugundhan, R. Soundaria, M. Maheswari, V. Santhakumari, P. And Gopal, V. 2011. "Hydroponics"- A Novel Alternative for Geoponic Cultivation of Medicinal Plants and Food Crops. *International Journal of Pharma and Sciences*.
- [4] G. L. Barbosa, F. D. A. Gadelha, N. Kublik, A. Proctor, L. Reichelm, E. Weissinger, G. M. Wohleb and R. U. Halden, 2015. Comparison of Land, Water and Energy Requirements of Lettuce Grown Using Hydroponic vs. Conventional Agriculture Method. *International Journal of Environmental Research and Public Health*.
- [5] ATmel 8-bit AVR Microcontroller with 4/8/16/32K Bytes In-System Programmable Flash. [Online]. From: <http://www.atmel.com/images/doc8161.pdf> [Accessed on September 2015].
- [6] Introduction of Thermoelectric Coolers [Online]. From: http://www.deltron.ch/pdf/produkte/peltier/kuehleinheit_kerlaert_e.pdf [Accessed on 24 September 2015].
- [7] K. Kobayashi, T. Amore, and M. Lazaro. 2013. Light-Emitting Diodes (LEDs) for Miniature Hydroponic Lettuce Miniature Optics and Photonics Journal, 3, 74-77.
- [8] S. Siregar. 2014. Solar Panel and Battery Street Light Monitoring System Using GPRS Communication System. *International Journal of Applied Engineering Research (IAER)*.

AUTOMATIONSYSTEM HYDROPONIC USING SMART SOLAR POWER PLANT UNIT

ORIGINALITY REPORT

15%

SIMILARITY INDEX

PRIMARY SOURCES

1	www.mdpi.com Internet	63 words — 2%
2	www.ijpbs.net Internet	52 words — 2%
3	www.deltron.ch Internet	45 words — 2%
4	climate.asu.edu Internet	43 words — 1%
5	www.seedbuzz.com Internet	35 words — 1%
6	Siregar, Simon, and Duddy Soegiarto. "Solar panel and battery street light monitoring system using GSM wireless communication system", 2014 2nd International Conference on Information and Communication Technology (ICoICT), 2014. Crossref	33 words — 1%
7	www.conftool.com Internet	31 words — 1%
8	www.ijareeie.com Internet	27 words — 1%
9	m.scirp.org Internet	19 words — 1%

10	www.scirp.org Internet	19 words — 1%
11	www.arduino.nu Internet	18 words — 1%
12	ag.arizona.edu Internet	18 words — 1%
13	pt.scribd.com Internet	15 words — 1%
14	dcl.isti.cnr.it Internet	14 words — < 1%
15	Barbosa, Guilherme, Francisca Gadelha, Natalya Kublik, Alan Proctor, Lucas Reichelm, Emily Weissinger, Gregory Wohlleb, and Rolf Halden. "Comparison of Land, Water, and Energy Requirements of Lettuce Grown Using Hydroponic vs. Conventional Agricultural Methods", International Journal of Environmental Research and Public Health, 2015. Crossref	6 words — < 1%

EXCLUDE QUOTES ON
EXCLUDE BIBLIOGRAPHY ON

EXCLUDE MATCHES OFF